

A study of the frictional characteristics of four commercially available self-ligating bracket systems

Steven Budd*, John Daskalogiannakis** and Bryan D. Tompson**

*Private practice, Langley, British Columbia and **Department of Orthodontics, University of Toronto, Ontario, Canada

SUMMARY The objective of this investigation was to assess and compare the *in vitro* tribological behaviour of four commercially available self-ligating bracket systems. The frictional characteristics of the Damon3™, Speed™, In-Ovation R™, and Time2™ bracket systems were studied using a jig that mimics the three-dimensional movements that occur during sliding mechanics. Each bracket system was tested on the following stainless steel archwires: 0.016 × 0.022, 0.019 × 0.025, 0.020 round, and 0.021 × 0.021 inch Speed™ D-wire. An Instron testing machine with a 50 N load cell was used to measure the frictional resistance for each bracket/tooth assembly. The crosshead speed was set at a constant rate of 1 mm/minute, and each typodont tooth was moved along a fixed wire segment for a distance of 8 mm. Descriptive statistical analysis for each bracket/archwire combination with regard to frictional resistance was performed with a two-way, balanced analysis of variance for bracket type and wire size.

The Damon3™ bracket consistently demonstrated the lowest frictional resistance to sliding, while the Speed™ bracket produced significantly ($P < 0.001$) more frictional resistance than the other brackets tested for any given archwire.

The self-ligation design (passive versus active) appears to be the primary variable responsible for the frictional resistance generated by self-ligating brackets during translation. Passively ligated brackets produce less frictional resistance; however, this decreased friction may result in decreased control compared with actively ligated systems.

Introduction

The use of sliding mechanics is a common approach for tooth movement in orthodontics. Used in space closure or distalization of teeth, it involves relative motion between the bracket and the archwire resulting in the generation of frictional resistance at their interface.

Friction is a force that resists the relative motion of two contacting bodies in a direction tangential to the plane of contact. Its magnitude, FT , is the product of the normal force, FN , times the coefficient of friction, μ , as per the formula $FT = \mu \times FN$ (Kapila *et al.*, 1990). The classic laws of dry friction state that it is independent of both the area of contact between the two sliding bodies and the sliding velocity; however, frictional force is proportional to the normal force acting perpendicular to the area of contact (Jastrzebski, 1987).

In orthodontics, friction is often held accountable for slowing down the rate of tooth movement and potentially causing loss of anchorage. This has led to various efforts aimed at the reduction of friction at the bracket/archwire interface. On the other hand, it has been argued that friction is of limited significance in the clinical setting. Random perturbations and vibrations from occlusal contacts during chewing and other functional activities (Braun *et al.*, 1999) as well as the ambiguous lubricating effect of saliva (Baker *et al.*, 1987; Thorstenson and Kusy, 2002) may reduce

frictional resistance significantly at the bracket/archwire interface.

Rather than occurring as a continuous, smooth, gliding process, tooth movement associated with sliding mechanics is known to occur as a series of minute tipping and uprighting movements. Because the force initiating motion is applied at a distance from the centre of resistance (CR), a moment is created that causes the tooth to tip until contact is established between the archwire and diagonally opposing aspects of the bracket slot. The tooth also rotates about its long axis until the archwire contacts the base of the bracket on the one side and the ligature or buccal clip on the other. Following these initial movements, the interaction of the bracket (and ligature) with the archwire causes the tooth to upright and derotate and the cycle is repeated as long as the initiating force remains in effect (Garner *et al.*, 1986). It does not appear that this has been reproduced in a laboratory setting.

Canine retraction (perhaps the most common clinical application of sliding mechanics) implies tooth movement on a segment of the archwire rigidly supported on either side of the canine (Braun *et al.*, 1999). In contrast to that, the popular experimental set-up of drawing a straight segment of wire through a bracket slot would correspond to a situation of tooth movement on a cantilever, as the wire is constrained only at one end. This type of constraint affects

the mechanical loading at the bracket/archwire interface and consequently the measured frictional resistance.

Self-ligation seems to be gaining more and more popularity in contemporary orthodontics. Compared with conventional appliances, all the commercially available self-ligating mechanisms attribute their increased efficiency and reduced treatment time to their improved frictional characteristics. However, considerable variation exists between commercially available bracket types in terms of their mechanical, geometric, and material-related specifications, and this would be expected to affect their frictional performance.

For these reasons, it was considered important to test the frictional behaviour of four commercially available self-ligating brackets with various archwire combinations under conditions that would allow replication (from a mechanical standpoint) of the clinical situation, by allowing the tooth to move freely under the influence of the traction force.

Materials and methods

Bracket/archwire combinations

The following self-ligating bracket systems (Figure 1) were compared with respect to their frictional behaviour: Time2™ (American Orthodontics, Sheboygan, Wisconsin, USA), In-Ovation R™ (GAC International, Islandia, New York, USA), Speed™ (Strite Industries, Cambridge, Ontario, Canada), and Damon System 3™ (Ormco/Sybron, Orange, California, USA). The brackets were tested on straight

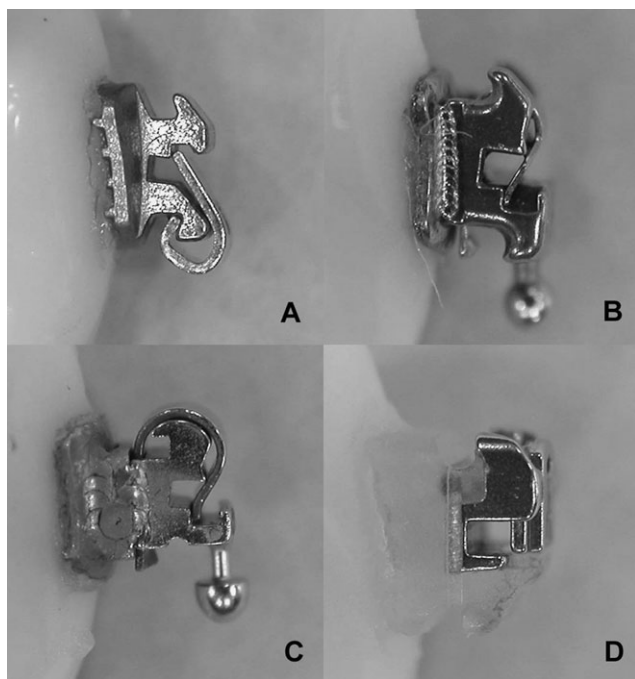

Figure 1 Profile views of Time2™ (A), In-Ovation R™ (B), Speed™ (C), and Damon System 3™ (D).

lengths of the following commercially available stainless steel (SS) orthodontic wires: 0.016 × 0.022 inch rectangular (3M Unitek, Monrovia, California, USA), 0.019 × 0.025 inch rectangular (3M Unitek), 0.020 inch round (3M Unitek), and 0.021 × 0.021 inch D-wire (Strite Industries). All brackets had a 0.022 inch slot size and a –7 degree torque prescription (maxillary right first premolar brackets). Unfortunately, complete standardization with regard to prescription and slot size was not possible as the first premolar Speed™ brackets possess a –2 degree tip, whereas all other brackets had 0 degree tip. In addition, all brackets used had a slot depth of 0.028 inches, with the exception of the Damon™ brackets whose bracket slot depth was 0.027 inches deep.

Test apparatus

An experimental testing jig (Figure 2) was designed that allowed the bracket/tooth assembly to move freely under the influence of a traction force. A fluid polymer (Dow Corning 200® Fluid, Dow Corning, Midland, Michigan, USA) with a viscosity of 100 000 centistokes (CST) was the medium used to provide resistance to movement so that the clinical situation of tipping and rotation following application of the force could be simulated. The consistency of the 200® Fluid is highly independent of temperature and easily reproducible between experiments. The traction force for the bracket/tooth assembly was provided by a vertically mounted crosshead of an Instron universal testing machine (model 4301, Instron Inc., Canton, Massachusetts, USA) equipped with a data-processing system. The Instron machine was connected to the bracket/tooth assembly by a flexible, low-creep cord that was tied directly to the body of the bracket to be tested (under the wire) via a pulley system.

Each bracket was bonded to a maxillary right first premolar melamine typodont tooth (Kilgore International Inc., Coldwater, Michigan, USA) with Transbond XT adhesive primer/Transbond XT resin (3M Unitek) and light cured for 20 seconds. A height gauge and graph paper were used to

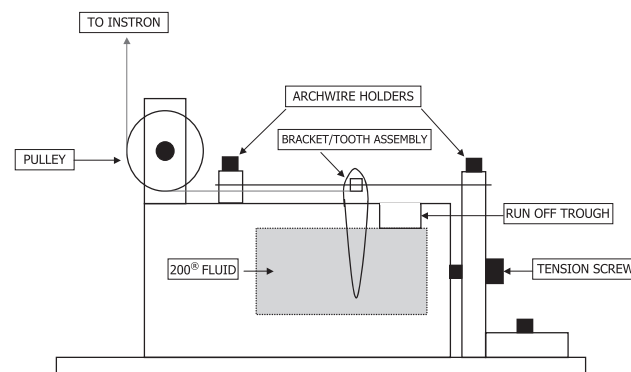

Figure 2 Schematic line drawing of custom-made friction-testing jig.

ensure that the different brackets were bonded with the slot at 4.0 mm from the buccal cusp tip (Figure 3A). Once the initial bracket/tooth assembly for each bracket type was bonded, a polyvinylsiloxane (PVS) jig was constructed to ensure that subsequent brackets of that type were bonded at the same height and orientation (Figure 3B).

Testing procedure

The root of each typodont tooth was submerged 13 mm in the polymer medium. The level of the 200[®] Fluid was kept constant throughout the experiment. Between test runs, the fluid that was removed with the previously tested tooth/bracket assembly was replenished. To ensure that the level of fluid was invariable, a run-off trough was constructed in the jig that would drain off excess fluid.

On either side of the container carrying the fluid, two vice-like holders clamped the ends of a straight length of wire that would guide the tooth movement. Once the wire was securely clamped in place, a tension screw was activated by one-quarter turn to impart a consistent degree of rigidity to the system. The wire was engaged in the bracket to be tested and the system was left for 1–2 minutes to ensure that the viscous medium reached a passive state prior to initiation of tooth movement. No additional means of ligation was used. A new bracket/tooth assembly and a new wire were used for each test run.

The Instron universal testing machine was fitted with a 50 N load cell calibrated to a full-scale load of 12.5 N. The crosshead speed was set at a constant rate of 1 mm per minute and the typodont teeth were moved along the fixed wire segments for a distance of 12 mm.

Data collection

The data were recorded on an *x-y* recorder. The *x*-axis represents tooth displacement in millimetres and the *y*-axis the resistance to the crosshead movement in newtons. Ten test sessions were conducted for each bracket/archwire combination. Thus, four different types of brackets were tested on four archwires of different dimensions yielding a total of 160 individual Instron tests.

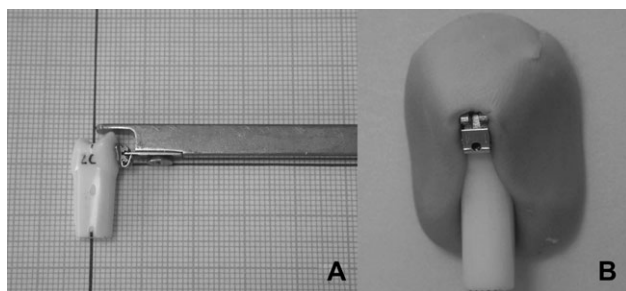

Figure 3 Bracket positioning gauge (A) and polyvinylsiloxane positioning jig (B).

Data analysis

One frictional resistance value for each of the 160 tests was calculated by determining the mean resistance recording on the *y*-axis once a steady state of resistance was reached. It was determined from a small series of pilot tests that the resistance level reached a plateau starting at no more than 4 mm displacement for all the bracket/archwire combinations. Therefore, the mean frictional resistance reading for each test run was determined by averaging the data sampling collected for the 8 mm distance (representing a premolar extraction space) between 4 and 12 mm (Figure 4). Descriptive statistics were then calculated for each bracket/wire combination with regard to frictional resistance. A two-way, balanced analysis of variance for bracket type and wire size was used for statistical analysis.

Results

Bracket interactions for a given wire

0.016 × 0.022 inch SS wire. With a mean resistance force of 1.1865 N, the Speed[™] bracket demonstrated significantly more resistance to movement ($P < 0.001$) than the other three brackets tested (Table 1). With a mean resistance force of 0.4637 N, the In-Ovation R[™] bracket displayed significantly more ($P < 0.001$) resistance to movement than the Damon3[™] or Time2[™]. At 0.1358 N and 0.0535 N, respectively, Time2[™] and Damon[™] brackets were not significantly different with regard to resistance to movement (Figure 5A).

0.019 × 0.025 inch SS wire. All brackets demonstrated significant differences to one another ($P < 0.001$). The Speed[™] bracket produced the most resistance to movement followed by In-Ovation R[™], Time2[™], and Damon3[™] (Figure 5B).

0.020 inch round SS wire. With a mean resistance force of 0.5352 N, Speed[™] produced significantly more resistance to

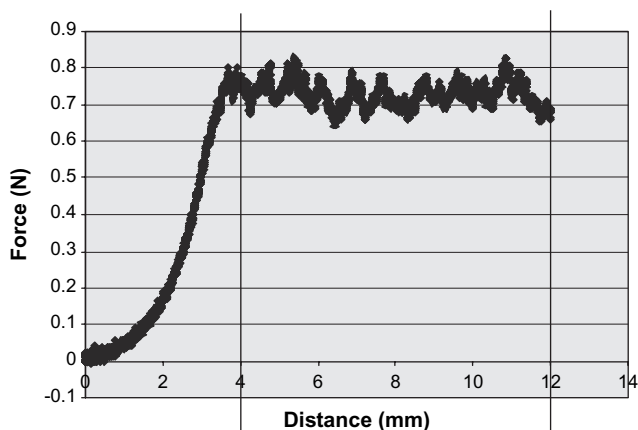

Figure 4 Example of the raw data obtained for each experimental test run. Mean resistance force values were obtained by averaging the force readings in the plateau region between 4 and 12 mm. An 8 mm plateau distance was chosen, representing the approximate mesiodistal width of a premolar extraction space.

Table 1 Mean resistance force values for bracket/wire couple ($N = 10$).

Bracket	Stainless steel wire (inches)	Mean resistance force (N)	Standard deviation
Damon3 TM	0.016 × 0.022	0.0535	0.0069
Damon3 TM	0.019 × 0.025	0.0542	0.0056
Damon3 TM	0.020	0.0170	0.0043
Damon3 TM	0.021 × 0.021 D	0.0704	0.0086
Time2 TM	0.016 × 0.022	0.1358	0.0347
Time2 TM	0.019 × 0.025	0.7842	0.0806
Time2 TM	0.020	0.0291	0.0106
Time2 TM	0.021 × 0.021 D	0.0591	0.0096
In-Ovation R TM	0.016 × 0.022	0.4637	0.1682
In-Ovation R TM	0.019 × 0.025	1.0847	0.2200
In-Ovation R TM	0.020	0.0194	0.0163
In-Ovation R TM	0.021 × 0.021 D	0.0869	0.0464
Speed TM	0.016 × 0.022	1.1865	0.3634
Speed TM	0.019 × 0.025	1.3568	0.4954
Speed TM	0.020	0.5352	0.1201
Speed TM	0.021 × 0.021 D	0.6360	0.1655

movement ($P < 0.001$) than the other three bracket systems. Time2TM, Damon3TM, and In-Ovation RTM showed no significant differences in sliding on this wire (Figure 5C). 0.021 × 0.021 inch SS D-wire. With a mean force of 0.6360 N, SpeedTM produced significantly more resistance to movement ($P < 0.001$) than the other three bracket systems. Time2TM, Damon3TM, and In-Ovation RTM showed no significant sliding differences on this wire (Figure 5D). The mean resistant forces generated by every bracket/wire combination tested are depicted in Figure 6.

Discussion

Jig design and testing procedure

Like most areas of orthodontics, the literature is divided when it comes to the frictional behaviour of orthodontic bracket systems. Given the objective nature of tribological testing, it would be reasonable to assume that bracket systems would behave fairly consistently when *in vitro* testing is performed. Unfortunately, most studies have not used an experimental testing jig that accurately mimics the three-dimensional movements that occur during sliding mechanics.

Drescher *et al.* (1989) pointed out that since the force applied to a tooth during sliding mechanics lies coronal and buccal to the CR, moments will be created causing the tooth to tip and rotate. Many studies have not factored these created moments into their experimental design. As a result, they involve a design whereby a straight segment of wire is simply pulled through a stationary horizontal bracket slot (Garner *et al.*, 1986; Berger, 1990; Hain *et al.*, 2003). This shortfall has been recognized and has led to experiments that incorporate bracket tip in the testing procedure.

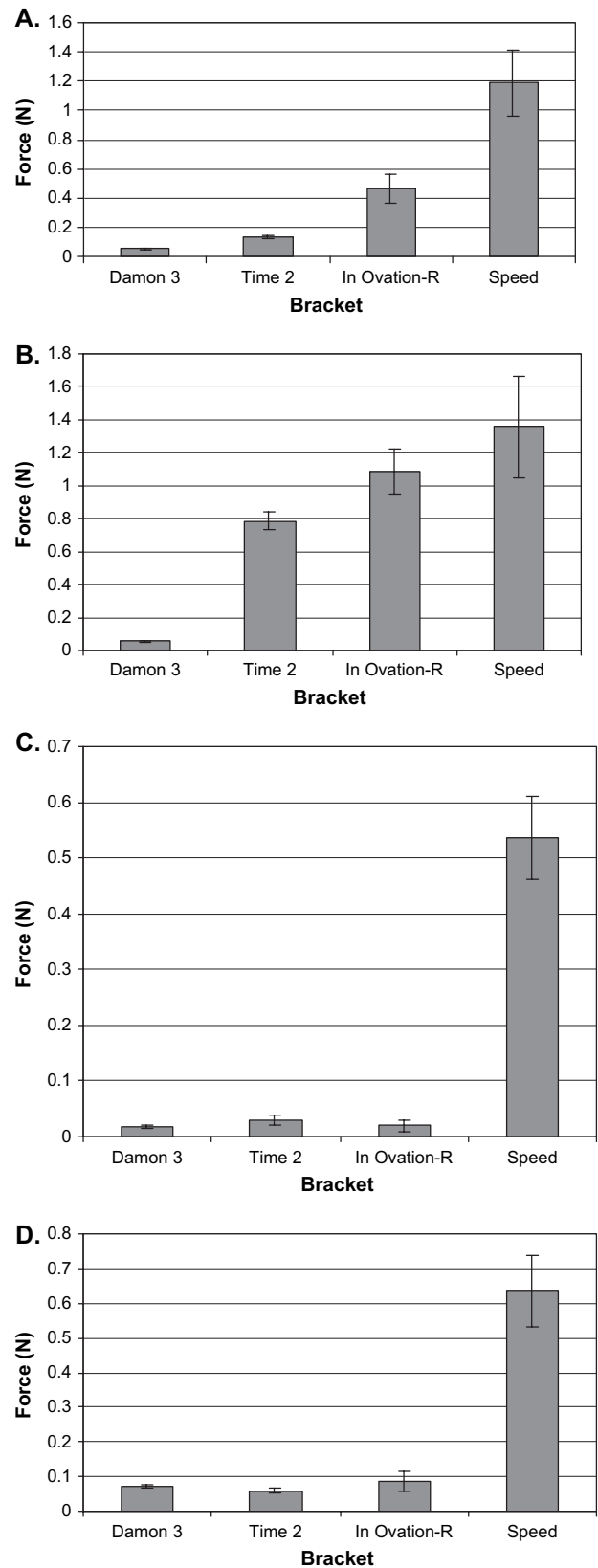

Figure 5 Mean resistance force per wire. (A) 0.016 × 0.022 inch stainless steel (SS). (B) 0.019 × 0.025 inch SS. (C) 0.020 inch round SS. (D) 0.021 × 0.021 inch SS SpeedTM D-wire.

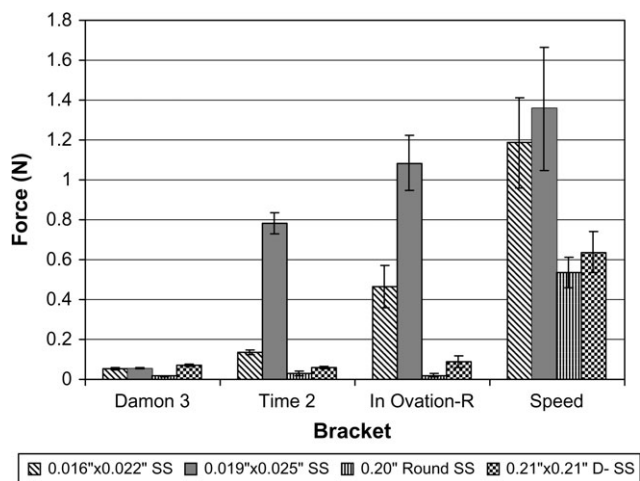

Figure 6 Comprehensive mean resistance force data.

Unfortunately, most of the experimental designs have maintained a fixed angle between bracket and archwire, essentially dragging the bracket along the archwire at a set angulation. In this manner, the anti-tip (uprighting) moment created *in vivo* by the elastic deformation at the bracket/archwire interface is overpowered. This would lead to permanent deformation of the archwire, greatly increasing measured resistance to movement.

Other studies were designed to account for the rotational moment created by the buccal application of the force with respect to the CR of a tooth. In an attempt to mimic the elasticity afforded by the periodontal ligament, Drescher *et al.* (1989) used foam rubber, while Loftus *et al.* (1999) used light body PVS as mediums in which to place their bracket/tooth assemblies. While their jig assemblies allowed for the initial tipping and rotation that would be observed *in vivo* by a bracket under the influence of a traction force, the experimental designs were such that the bracket position did not change once these initial moments had occurred, essentially having the same limitations as the studies mentioned above.

The primary objective of the present investigation was to find a way to mimic the tipping and uprighting movements that occur clinically during translation of a tooth. A substance was needed that was sufficiently viscous to provide significant resistance to create a CR for the bracket/tooth assembly, while at the same time being able to flow around the tooth to maintain a constant level of contact. In addition, the medium had to possess physical properties that were stable, to ensure a consistent testing environment. The 200[®] Fluid is a high viscosity (100 000 CST) polydimethylsiloxane polymer that combines high compressibility, high damping action, high oxidation resistance, high water repellency, low reactivity, low surface energy, and good heat stability. Pulling the root of each typodont tooth through this viscous medium provided a CR for the tooth so that tipping and rotational moments

were created as would be observed *in vivo*. In addition, the properties of the medium were such that they allowed the dynamic counter-moments created from the elastic deformation of the archwire to upright and derotate the tooth. This was certainly not an attempt to replicate the intricate biological processes created at the bone/periodontal ligament/cementum interface in the clinical situation. Instead, it was an effort to standardize the testing for all brackets, while still using a model that allowed an object (tooth) with a CR to be slid on an archwire creating a type of archwire/bracket interaction that is, from a force system standpoint, similar to that observed clinically.

It should be noted that the liquid nature of the medium allowed for a total expression of the bracket prescription, and thus the archwire was completely passive in the bracket slot prior to traction of the bracket/tooth. This may not be representative of a situation *in vivo* where adequate time may not be given to allow the bracket's prescription be expressed. In such a situation, the torque effects of rectangular wires and the tip effects of round and rectangular wires would profoundly influence frictional resistance due to increased binding and notching. Translation of such an actively engaged bracket along an archwire would not be representative of the present study's design model. As a result, the conclusions of the present investigation may not be applicable to clinical situations where adequate time has not been given to level the dentition and express any torque within the prescription.

Some criticism may be made of the jig design in that there was friction inherent within the testing apparatus (Figure 2). There is no doubt that a small amount of friction was produced from the contact between the pulley and the traction line and also within the pulley itself; however, as the focus of the present study was relative levels of frictional resistance, not absolute levels, any additional sources of friction were consistently similar in all tests.

According to Kusy and Whitley (1989), the standard accepted rate of bone remodelling of 1 mm/month translates to 2.3×10^{-5} mm/minute. Due to time limitations and mechanical considerations, it was decided that this would not be a practical rate at which to perform the experiments. However, according to the third law of classic friction, the coefficient of friction is independent of sliding velocity (Jastrzebski, 1987). An experiment by Kusy and Whitley (1989) confirmed that no significant differences for the coefficients of friction for SS flats and archwires existed with various sliding velocities between 10 and 0.0005 mm/minute. Thus, for this experiment, a speed of 1 mm/minute was chosen as it fulfilled two important criteria: it was slow enough to allow the 200[®] Fluid to freely flow around the tooth without any distal bunching or mesial trough formation, while at the same time it allowed for the experiment to be completed within a reasonable period of time.

Effect of bracket material

All the brackets tested possessed a SS slot. The Damon3™ and Time2™ brackets had a SS cap and clip, respectively. The spring clip on the In-Ovation R™ bracket was made of cobalt–chromium (Co–Cr), while that on the Speed™ bracket was made of nickel–titanium (Ni–Ti). Since the jig design allowed for rotation of the bracket/tooth assembly about the long axis of the tooth, as the tooth rotates, the SS archwire will contact the distal margin of the buccal clip/spring clip. The coefficients of friction of different alloys against SS have been shown to be (in decreasing order): β -titanium (highest), Ni–Ti, Co–Cr, and SS (lowest; Kusy *et al.*, 1988; Kusy and Whitley, 1989, 1990). The Damon3™ and Time2™ brackets both possessed SS slots and self-ligating caps/clips; therefore, only couples of SS/SS are formed when sliding these brackets on SS archwires. In the case of the In-Ovation R™ and Speed™ brackets, however, couples of Co–Cr/SS and Ni–Ti/SS, respectively, are created in addition to SS/SS couples, while sliding on SS archwires. Interestingly, the hierarchy of resistance to movement obtained from the results of this study match the hierarchy of coefficients of friction as stated by Kusy and Whitley (1989, 1990). This may lead one to believe that the different cap/clip materials were in fact responsible for some of the differences seen with resistance to movement.

Effect of ligation mechanism (passive versus active self-ligation)

The results of this experiment indicate that bracket design is paramount when examining the frictional characteristics of self-ligating bracket systems. Of the four self-ligating bracket systems tested, the Damon3™ bracket is unique in that it possesses a ‘passive’ cap as opposed to an ‘active’ clip mechanism to retain the archwire. This cap essentially converts the bracket slot into a tube and thus places no active force on the archwire once the teeth have been levelled and aligned.

The Time2™, In-Ovation R™, and Speed™ brackets possess active clips that deliver an active force that seats the archwire into the slot, but only after the archwire exceeds a certain bucco-lingual dimension. The Time2™ ligation mechanism consists of a rigid SS clip that swings down on a hinge to lock the archwire into the bracket slot. It is defined as active in that it will impinge upon the slot and impose a seating force on the archwire if the archwire is not fully seated to begin with, or if a fully seated archwire exceeds approximately 0.018 inches in the bucco-lingual dimension. Interestingly, the present study showed that the clip on the Time2™ bracket did not appear to actively engage the archwire until a bucco-lingual dimension of 0.021 inches was exceeded. This was possibly due to the fact that once the clip was closed, the archwire sat passively on the gingival floor of the bracket slot where the amount of bucco-lingual clearance was

greater (Figure 1A). Due to its rigid nature, the clip itself possesses no elastic energy. In this respect, once closed, the bracket behaves similarly to the Damon3™ bracket, assuming the archwire is sitting passively within the bracket slot. This may explain the finding of no significant differences between Time2™ and Damon3™ in resistance to movement for all wires tested, with the exception of the 0.019×0.025 inch SS.

The In-Ovation R™ bracket, in particular, is marketed as having a ‘passive–active’ clip system. This refers to the fact that round wires less than 0.020 inches in diameter sit passively in the slot, with no force being delivered from the clip. Any wire with a bucco-lingual dimension larger than 0.020 inches will receive a greater amount of force from the actively displaced Co–Cr clip, thereby delivering greater rotational control and, in the case of a rectangular wire, greater torque control.

The Speed™ bracket ligation mechanism consists of an elastic Ni–Ti clip that imparts a constant force on the archwire after it exceeds approximately 0.0175 inches in the bucco-lingual dimension. Of the four brackets tested, the active clip of the Speed™ bracket impinged upon the bracket slot to the greatest extent. This resulted in greater activation (deflection) of the elastic clip compared with the In-Ovation R™’s passive–active elastic clip. The design theory is that the elastic Ni–Ti clip will deliver a constant seating force to the archwire that will result in superior rotational and torque (in the case of a rectangular wire) control. It is conceivable that this increase in torque and rotational control comes at the expense of an increased normal force and thus greater frictional resistance. This concurs with the results of the present study where it was found that the Speed™ bracket produced significantly more resistance to movement than the other brackets tested, for any given archwire. This is also in agreement with the findings of Thorstenson and Kusy (2002) who determined that brackets with active clips produced frictional forces as great as 50 times that of brackets with passively ligating caps.

Effect of geometric dimensions

Other than the self-ligation mechanism, the greatest source of variability between the brackets tested comes from differences in geometric design, resulting in differences in contact angles and surface area.

Drescher *et al.* (1989), Tidy (1989), and Sims *et al.* (1994) reported that wider brackets produced less friction than narrow brackets, by allowing less angulation change of the archwire. From the manufacturers’ specifications (Table 2), it can be seen that the Speed™ bracket, at 2.032 mm, was by far the narrowest of the brackets tested. The Time2™ and In-Ovation R™ brackets had the widest slot dimensions at 2.946 and 3.000 mm, respectively, while the Damon3™ had an intermediate width of 2.667 mm. While

Table 2 Bracket specifications.

Bracket	Speed™	In-Ovation R™	Time2™	Damon3™
Slot size (inches)	0.022 × 0.028	0.022 × 0.028	0.022 × 0.028	0.022 × 0.027
Slot width (mm)	2.032	3.0	2.946	2.667
Tip (degrees)	-2	0	0	0
Torque (degrees)	-7	-7	-7	-7
Slot composition	stainless steel	stainless steel	stainless steel	stainless steel
Clip composition	nickel-titanium	cobalt-chromium	stainless steel	stainless steel

the Speed™ bracket consistently produced the greatest amount of resistance to sliding, the Damon3™ bracket consistently produced the least amount of resistance for all tested wires. If bracket width was the primary variable in determining frictional resistance, one would expect the Damon3™ bracket to produce mean resistance forces somewhere between that of the narrow Speed™ and the wider Time2™ and In-Ovation R™ brackets. The present results suggest that bracket width is a variable of secondary importance in determining frictional resistance of self-ligating brackets.

Since the present study permitted some tipping and rotation, two different contact angles must be considered: the first formed between the archwire and bracket slot due to tipping and the second that between the archwire and the base of the bracket on one side and the self-ligating clip/cap on the other due to rotation. Andreasen and Quevedo (1970), Frank and Nikolai (1980), Sims *et al.* (1994), and Ogata *et al.* (1996) are just a few of the investigators who have shown that frictional resistance increases as the contact angle (θ) increases between the bracket and archwire due to tipping. While the occluso-gingival height of the slot for all the brackets used was 0.022 inches, the Damon3™ was unique in that its slot was 0.027 inches deep, as opposed to the standard 0.028 inches for the other brackets. The smaller bucco-lingual slot dimension means that as the tooth rotates around its long axis under application of a force, the buccal cap will contact the archwire sooner than with the standard slot depth. Therefore, a smaller contact angle will be created between the archwire and the buccal cap. This would lead one to believe that for a given archwire size the Damon3™ may have a slight advantage over other brackets that possess a standard 0.022 × 0.028 inch slot.

A study by Berger (1990) addressed the effect of surface area between the archwire and the bracket slot on frictional resistance. That author considered that the Speed™ bracket system may possess a slight advantage over wider brackets due to a decreased amount of surface area from a narrower slot. However, this is in direct conflict with the classic laws of friction that state that friction is independent of surface area (Jastrzebski, 1987). The argument that classic laws of friction do not apply in this case is not justified because the experimental set-up design used by Berger (1990) had

the bracket/archwire in a passive configuration in which the archwire was drawn parallel to the bracket slot. Kusy and Whitley (1999) stated that resistance to sliding can be divided into three components: classical friction, binding, and notching. They noted that in a passive configuration where the bracket/archwire contact angle is less than a critical value, binding and notching are insignificant. Other investigators have also warned against ignoring the *in vivo* effects of bracket tipping since it contributes greatly to the total normal force exerted on the archwire (Iwasaki *et al.*, 2003).

Effect of surface roughness

One final variable that should be discussed is the effect of the finish of the bracket slot surface. Conceivably, large differences in surface roughness could affect resistance to movement by increasing the frictional coefficient of the material. Jastrzebski (1987) stated that interlocking of surface asperities can have a significant effect on frictional resistance, as shearing of the interlocking protuberances is necessary for movement to occur. However, the author pointed out that this type of frictional resistance is usually insignificant as most engineering surfaces are relatively smooth. Unfortunately, surface roughness of the various bracket slots was not within the parameters examined in the present research.

Effect of archwire cross-sectional shape and size

The results of this study indicate that bracket design is highly significant when examining the frictional characteristics of self-ligating bracket systems.

The Damon3™ showed no significant differences in resistance to movement for any of the archwires tested. These results are in agreement with Tidy (1989) and Ireland *et al.* (1991) who observed that wire dimension was not a significant factor with SS wires with regard to frictional resistance. The Time2™ bracket only showed a significant increase in resistance to movement while sliding on the 0.019 × 0.025 inch SS archwire. Given the fact that both brackets possess SS slots with SS caps/clips, it is possible that it is the difference in the ligating mechanism that is responsible for the significantly larger mean resistance force

of the Time2™ bracket with the 0.019 × 0.025 inch SS wire. Unlike Drescher *et al.* (1989) who found the vertical dimension of the archwire to be important in determining frictional resistance, the results of the present study showed the opposite. Increases in vertical wire dimension from 0.016 to 0.021 inches actually demonstrated a decrease in frictional resistance or no significant change. These results agree with Baker *et al.* (1987) who considered that archwires of greater vertical dimension will result in decreased play between bracket slot and archwire, producing less wire angulation within the slot, and creating less potential for binding and ultimately a smaller normal force.

The wire dimension in the bucco-lingual direction appears to be a more important factor in the friction generated by self-ligating brackets. With the exception of the Damon3™ bracket, increases in the bucco-lingual dimension generally resulted in significant increases in the mean resistance force generated. This trend appeared to also be true as wire cross-sectional shape changed from round to rectangular. These results agree with Andreasen and Quevedo (1970), Riley *et al.* (1979), Angolkar *et al.* (1990), Kapila *et al.* (1990), Sims *et al.* (1993), Downing *et al.* (1994), and Ogata *et al.* (1996), who concluded that frictional resistance is increased with increases in archwire dimension and/or changes in the cross-sectional shape of the archwire (from round to rectangular). Interestingly, the D-wire, which represents somewhat of a transition from round to rectangular archwire, generally displayed mean resistance forces between those generated by the round and rectangular archwires. It is likely that the differences observed with archwire dimension and cross-sectional shape are largely a result of the self-ligation mechanism for each bracket. Archwire sizes and shapes that allow for passive configuration will result in less frictional resistance than those where the clip is applying an active force to the archwire.

Conclusions

1. The passively ligated Damon3™ bracket system consistently demonstrated levels of resistance to movement that were either not statistically significantly different or were statistically significantly lower than any of the other three brackets tested.
2. The actively ligated Speed™ bracket system consistently demonstrated levels of resistance to movement that were statistically significantly higher than any of the other three brackets tested for any given archwire.
3. The self-ligation design (passive versus active) appeared to be the primary variable responsible for resistance to movement generated in self-ligating brackets. Passively ligated brackets produced decreased amounts of resistance; however, this decreased resistance may come at the cost of decreased control compared with actively ligated systems.
4. Archwire size and shape appeared to have a more profound influence on mean resistance force generated when actively ligated brackets were considered. In general, resistance to movement increased with increases in archwire dimension and/or changes in cross-sectional shape of the archwire (from round to rectangular).
5. The bucco-lingual dimension (thickness) of the wire appeared to be a more important factor than the occluso-gingival dimension in determining the frictional resistance of self-ligating brackets under the conditions of the study.

Address for correspondence

Dr John Daskalogiannakis
 Department of Orthodontics
 University of Toronto
 124 Edward Street
 Toronto
 Ontario
 Canada M5G 1G6
 E-mail: john.daskalogiannakis@utoronto.ca

References

- Andreasen G F, Quevedo F R 1970 Evaluation of frictional forces in the 0.022 × 0.028 edgewise bracket *in vitro*. *Journal of Biomechanics* 3: 151–160
- Angolkar P V, Kapila S, Duncanson M G, Nanda R S 1990 Evaluation of friction between ceramic brackets and orthodontic wires of four alloys. *American Journal of Orthodontics and Dentofacial Orthopedics* 98: 499–506
- Baker K L, Nieberg L G, Weimer A D, Hanna M 1987 Frictional changes in force values caused by saliva substitution. *American Journal of Orthodontics and Dentofacial Orthopedics* 91: 316–320
- Berger J L 1990 The influence of the Speed bracket's self-ligating design on force levels in tooth movement: a comparative *in vitro* study. *American Journal of Orthodontics and Dentofacial Orthopedics* 97: 219–228
- Braun S, Bluestein M, Moore B K, Benson G 1999 Friction in perspective. *American Journal of Orthodontics and Dentofacial Orthopedics* 115: 619–627
- Downing A, McCabe J, Gordon P 1994 A study of frictional force between orthodontic brackets and archwires. *British Journal Orthodontics* 21: 349–357
- Drescher D, Bourauel C, Schumacher H-A 1989 Frictional forces between bracket and archwire. *American Journal of Orthodontics and Dentofacial Orthopedics* 96: 397–404
- Frank C A, Nikolai R J 1980 A comparative study of frictional resistance between orthodontic bracket and archwire. *American Journal of Orthodontics* 78: 593–609
- Garner L D, Allai W W, Moore B K 1986 A comparison of frictional forces during simulated canine retraction on a continuous edgewise archwire. *American Journal of Orthodontics and Dentofacial Orthopedics* 90: 199–203
- Hain M, Dhopatkar A, Rock P 2003 The effect of ligation method on friction in sliding mechanics. *American Journal of Orthodontics and Dentofacial Orthopedics* 123: 416–422
- Ireland A J, Sherriff M, McDonald F 1991 Effect of bracket and wire composition of frictional forces. *European Journal of Orthodontics* 13: 322–328

- Iwasaki L R, Beatty M W, Nickel J C 2003 Friction and orthodontic mechanics: clinical studies of moment and ligation effects. *Seminars in Orthodontics* 9: 290–297
- Jastrzebski Z D 1987 *The nature and properties of engineering materials* 3rd edn. Wiley & Sons, New York
- Kapila S, Angolkar P V, Duncanson M G, Nanda R S 1990 Evaluation of friction between edgewise stainless steel brackets and orthodontic wires of four alloys. *American Journal of Orthodontics and Dentofacial Orthopedics* 98: 117–126
- Kusy R P, Whitley J Q 1989 Effects of sliding velocity on the coefficients of friction in a model orthodontic system. *Dental Materials* 5: 235–240
- Kusy R P, Whitley J Q 1990 Effects of surface roughness on the coefficients of friction in model orthodontic systems. *Journal of Biomechanics* 23: 913–925
- Kusy R P, Whitley J Q 1999 Influence of archwire and bracket dimensions on sliding mechanics: derivations and determinations of the critical contact angles for binding. *European Journal of Orthodontics* 21: 199–208
- Kusy R P, Whitley J Q, Mayhew M J, Buckthal J E 1988 Surface roughness of orthodontic archwires via laser spectroscopy. *The Angle Orthodontist* 58: 33–45
- Loftus B P, Årtun J, Nicholls J I, Alonzo T A, Stoner J A 1999 Evaluation of friction during sliding tooth movement in various bracket-archwire combinations. *American Journal of Orthodontics and Dentofacial Orthopedics* 116: 336–345
- Ogata R H, Nanda R S, Duncanson M G, Sinha P K, Currier G F 1996 Frictional resistances in stainless steel bracket wire combinations with effects of vertical deflections. *American Journal of Orthodontics and Dentofacial Orthopedics* 109: 535–542
- Riley J L, Garrett S G, Moon P C 1979 Frictional forces of ligated plastic and metal edgewise brackets. *Journal of Dental Research* 58: 98 (abstract)
- Sims A P T, Waters N E, Birnie D J, Pethybridge R J 1993 A comparison of the forces required to produce tooth movement *in vitro* using two self ligating brackets and a preadjusted bracket employing two types of ligation. *European Journal of Orthodontics* 15: 377–385
- Sims A P, Waters N E, Birnie D J 1994 A comparison of the forces required to produce tooth movement *ex vivo* through three types of pre-adjusted brackets when subjected to determined tip or torque values. *British Journal of Orthodontics* 21: 367–373
- Thorstenson G A, Kusy R P 2002 Comparison of resistance to sliding between different self-ligating brackets with second-order angulation in the dry and saliva states. *American Journal of Orthodontics and Dentofacial Orthopedics* 121: 472–482
- Tidy D C 1989 Frictional forces in fixed appliances. *American Journal of Orthodontics and Dentofacial Orthopedics* 96: 249–254